

Shape

DESIGN: PAOLO BISTACCHI



Shape

Mod. Com. (2006)

Apparecchio da incasso a luce diretta e diffusa, disponibile in due versioni: quadrato e circolare. Frontale estraibile composto da cornice in acciaio verniciato a polvere e vetro di protezione temperato satinato. Vano lampada ispezionabile tramite apertura a scatto. Versioni per lampade alogene a tensione di rete, a bassissima tensione 12 V (SELV) con trasformatore remoto, oppure per lampade a scarica Mini Master Colour con alimentazione elettronica separata. Disponibile nelle finiture: bianco e alluminio satinato.

Recessed luminaries featuring direct/diffused light output, available in two versions: cubic and round. Removable front panel, composed from a powder coated steel frame and a tempered protection satin glass. Mechanical click-in front panel to ease periodic servicing. Mains voltage halogen lamps, safety extra-low voltage 12 V (SELV) with remote transformer or Mini Master Colour discharge lamps with electronic ballast. Available in the finishing: white and grey.

Einbauleuchte für direkte/diffuse Beleuchtung in zwei Varianten: quadratisch und rund. Vordere Abdeckung mit Rahmen aus pulverbeschichtetem Stahl und gleichmäßiger satiniertes Glasabdeckung. Klick-in Verschluss für werkzeuglose Wartungsarbeiten am Leuchtmittel. Versionen für einseitig gesockelte Hochvolt Halogenleuchtampen, Niedervolt-Halogenlampen 12 V (SELV) oder Mini Master Colour Entladungslampen mit separatem elektronischem Vorschaltgerät. Verfügbar in den Farben weiß und aluminium satiniert.

Appareil a emboîter à lumière directe et diffuse, disponible dans deux versions: carré et circulaire. Partie frontale qui peut être extraite composé par une armature en acier enduite de poudre et un verre de protection temperé satiné. Possibilité d'inspecter le logement lampe grâce à une ouverture à ressort. Versions pour lampes halogènes avec tension directe, à basse tension 12 V (SELV) avec transformateur reculé ou avec lampes a décharge Mini Master avec alimentation électronique séparée. Disponible dans les finitions: blanc et aluminium satiné.

Встраиваемый световой аппарат прямого рассеянного излучения, представленный в двух вариантах: квадратной и круглой формы. Съёмная передняя панель, состоящая из стального обрамления (покраска распылителем) и коленного матового стекла. Легкий доступ к внутренней части аппарата для проверки и замены лампы. Возможно применение галогенных ламп под сетевое напряжение и напряжение 12 V (SELV) при наличии трансформатора, а так же лампы типа Mini Master Color при наличии ЭПРА. Цвета обрамления: Белый и матовый алюминий.

Frontale estraibile tramite apertura a scatto, per facilitare gli interventi di manutenzione.

Mechanical click-in front panel to ease periodic servicing.

Klick-in Verschluss für werkzeuglose Wartungsarbeiten am Leuchtmittel

Partie frontale qui peut être extraite grâce à une ouverture à ressort, pour permettre les interventions de manutention sur l'appareil.

Съемная передняя панель рассчитана на облегчение проведения работ по обслуживанию аппарата.



Al fine di semplificare le operazioni di installazione del prodotto ad incasso, Shape Cubic non necessita di un foro quadrato, bensì tondo come quello di Shape Round.

In order to simplify the recessing of the fixture, Shape Cubic does not need to have a square hole in the ceiling, but just a round one, like the one of Shape Round.

Zur Vereinfachung der Installation der Einbauleuchte erfordert Shape Cubic kein quadratisches sondern ein rundes Loch, wie jenes von Shape Round.

Pour simplifier les opérations d'installation du produit a emboîter, Shape Cubic ne nécessite pas d'un trou carré, mais plutôt rond, comme celui de Shape Round.

С целью облегчения установки аппарата, Shape Cubic не нуждается в квадратном отверстии, отверстие также круглой формы как для Shape Round.

Shape Cubic

NRTL IP 40 - IP 20 750°C

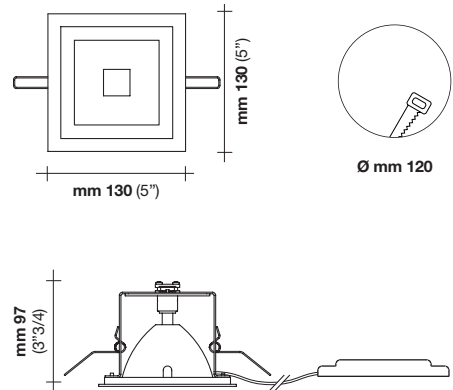

G9	Colore/Finish Ausführung Couleurs/Lpeet		
1x40W QT14		158221A.	17 05

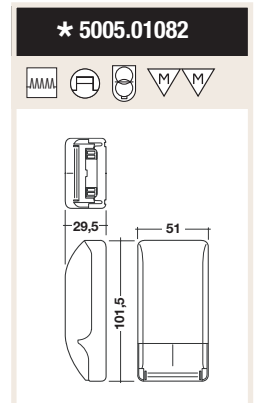
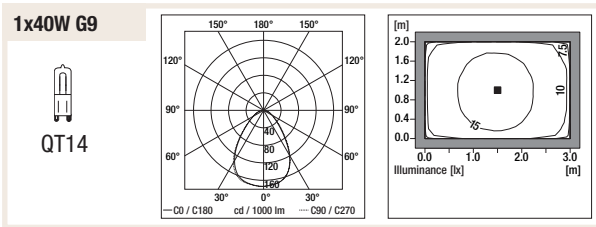

GY6,35	Colore/Finish Ausführung Couleurs/Lpeet		
1x50W 12V QT12		158434A.	17 05
+ Trasformatore 12V + Transformer 12V		5005.01082	

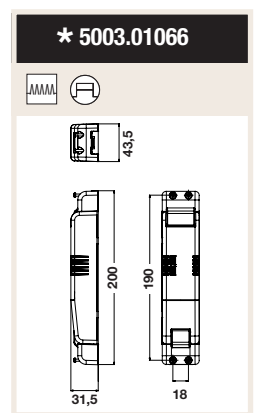
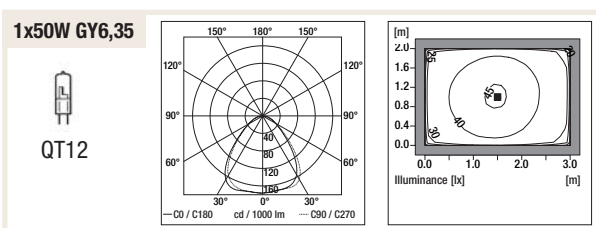

PGJ5	Colore/Finish Ausführung Couleurs/Lpeet		
1x20W HIT-TC-CE		158270A.	17 05
+ Alimentatore HIT 20W + Ballast HIT 20W		5003.01066	

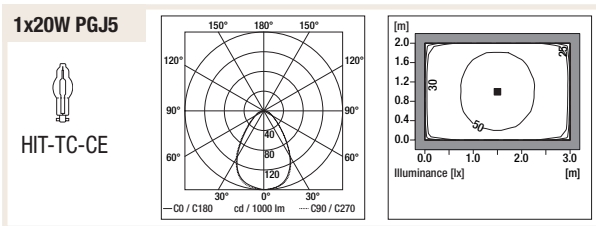

PGJ5	Colore/Finish Ausführung Couleurs/Lpeet		
1x35W HIT-TC-CE		158499A.	17 05
+ Alimentatore HIT 35W + Ballast HIT 35W		5003.01072	

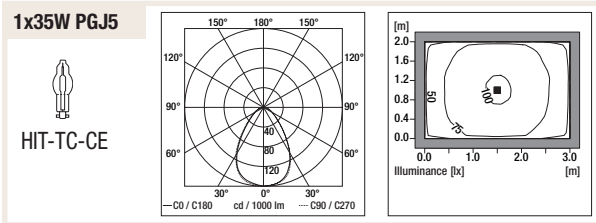

Shape Round

NRTL IP 40 - IP 20 750°C

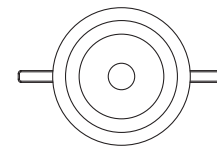

Ø mm 130 (5'')

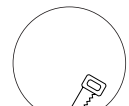

Ø mm 120

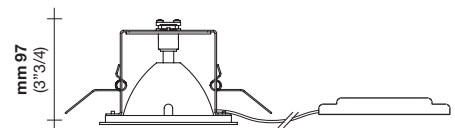

mm 97
(3' 3/4)

G9	Colore/Finish Ausführung Couleurs/L'æter
1x40W QT14	160221A. 17 05

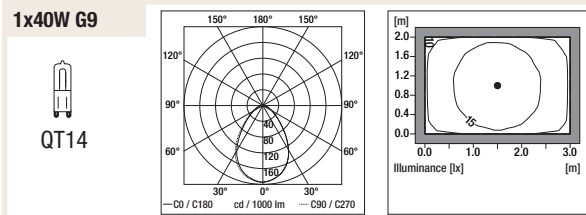

GY6,35	Colore/Finish Ausführung Couleurs/L'æter
1x50W 12V QT12	160434A. 17 05
+ Trasformatore 12V + Transformer 12V	5005.01082

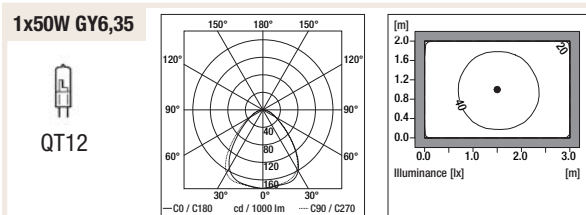

*** 5005.01082**

PGJ5	Colore/Finish Ausführung Couleurs/L'æter
1x20W HIT-TC-CE	160270A. 17 05
+ Alimentatore HIT 20W + Ballast HIT 20W	5003.01066

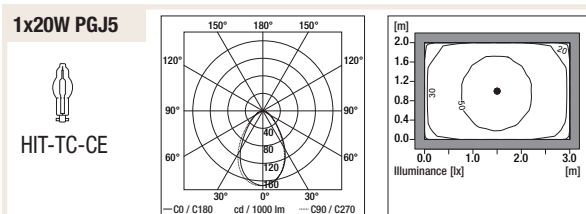

*** 5003.01066**

PGJ5	Colore/Finish Ausführung Couleurs/L'æter
1x35W HIT-TC-CE	160499A. 17 05
+ Alimentatore HIT 35W + Ballast HIT 35W	5003.01072

